

Single Line Systems

For a large number of lubrication points



Groeneveld-BEKA

Reducing customers' operational costs and at the same time increasing uptime, productivity, efficiency and safety of their vehicles and machines. That is what it's all about at Groeneveld-BEKA. We accomplish this by developing, producing, supplying and servicing industry-leading automatic lubrication, fluid control and safety support systems.

Groeneveld-BEKA, part of The Timken Company, is the world's second largest producer of automatic lubrication systems, fluid management and safety support systems. Groeneveld-BEKA products improve equipment lifetime and reliability, while reducing the total cost of ownership.

Groeneveld-BEKA was formed through the merger of two well-established companies: Groeneveld and BEKA. Groeneveld was founded in 1971 and acquired by Timken in 2017. BEKA was founded in 1927 and acquired by Timken in late 2019. Groeneveld has also incorporated Interlube into their brand. Interlube was acquired by Timken in 2013.

Groeneveld-BEKA products are supplied for ex-factory installs to leading manufacturers of trucks, trailers, buses, wind turbines, industrial applications, agricultural, mining and construction equipment. In addition Groeneveld-BEKA systems are installed in the after-market for a wide variety of transport, construction, agricultural, port equipment and industrial applications. Groeneveld-BEKA strives to develop and manufacture all of its products in-house according to World Class Manufacturing principles.

Automatic Lubrication Systems

Groeneveld-BEKA offers dedicated automatic lubrication systems for all kinds of equipment in a wide variety of market segments, from the smallest excavator to the largest trucks and industrial applications. The application of our high-end systems leads to decreased wear and tear of critical components resulting in extended lifetime, less downtime and reduced repair and maintenance costs. In short: higher productivity and lower operational costs. As maintenance technicians no longer have to climb on or crawl under the equipment, Groeneveld-BEKA's automatic lubrication systems also contribute to safety.

For optimal greasing in all circumstances Groeneveld-BEKA also offers the right type of grease for every application and every system. This is your guarantee for many years of trouble-free operation of your system and perfect lubrication of your valuable equipment.

Fluid Control

Groeneveld-BEKA's fluid management systems reduce daily maintenance and minimize the risk of unexpected downtime by controlling engine oil levels or removing contamination. Next to the oil management systems, Groeneveld-BEKA also offers systems which easily convey hydraulic power from fixed to moving points.

Safety Support Systems

For many years, Groeneveld-BEKA supplies safety support systems for a wide range of applications. Speedlimiters as well as obstacle detection and camera systems by Groeneveld-BEKA increase safety in many segments from road transport to construction, port, terminal and internal transport.

The World of Lubrication

Groeneveld-BEKA is a global enterprise with a worldwide coverage. In many countries, the company is also represented by independent distributors and dealers – all just as driven as our own organisation to offer added value to the customer's company.

With decades of experience providing reliability services to a range of industries, Groeneveld-BEKA offers complete automated maintenance solutions for all your needs. Groeneveld-BEKA's reliability products maintain your equipment, helping you increase uptime and improve profitability.

Visit the Groeneveld-BEKA website for contact details of our subsidiaries, distributors and service dealers.

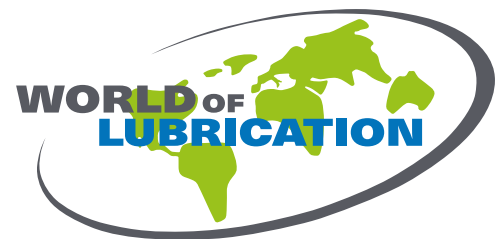

Less maintenance, improved efficiency and lower costs

In today's demanding industrial environment it is critical that machines generate an acceptable level of profit. Whether you are an owner, operator or a plant manager, one of the most cost effective ways of achieving this objective is by employing the use of fully automatic lubrication systems.

Groeneveld-BEKA's automatic lubrication systems have been proven to extend bearing life compared with manual greasing, dramatically cutting the cost of bearing replacements, reducing downtime and improving efficiency and safety.

The benefits

The benefits of automatic lubrication are clear: better greasing of critical components, no time wasted on manual lubrication and the certainty that the equipment will always be greased independent of weather conditions, time schedules or operators. All resulting in significant cost savings.

Reduced man-hours required to lubricate.

- Improved availability of personnel for technical activities.
- Reduced lubricant spillage that occurs with manual lubrication.

Higher equipment productivity

Reduced equipment downtime by ca. 15% resulting from:

- Lubrication taking place during normal machine operation.
- Better and uniform greasing of all critical components because bearings and pins and bushings are in motion when lubrication takes place, resulting in less wear and tear of machinery.

Decreased maintenance

- With manual lubrication, grease will follow the path of least resistance due to the fact that greasing has to take place under static conditions. So, the grease is not equally distributed around the lubrication point. Automatic greasing avoids this, as lubrication will take place during operation, reducing wear of critical components.
- Reduced replacement rate of components and bearings up to 50%.
- Decreased machine labour costs by ~ 50%.

Improved safety

- No climbing on and around machinery or inaccessible areas.

Effectiveness of Automatic Lubrication

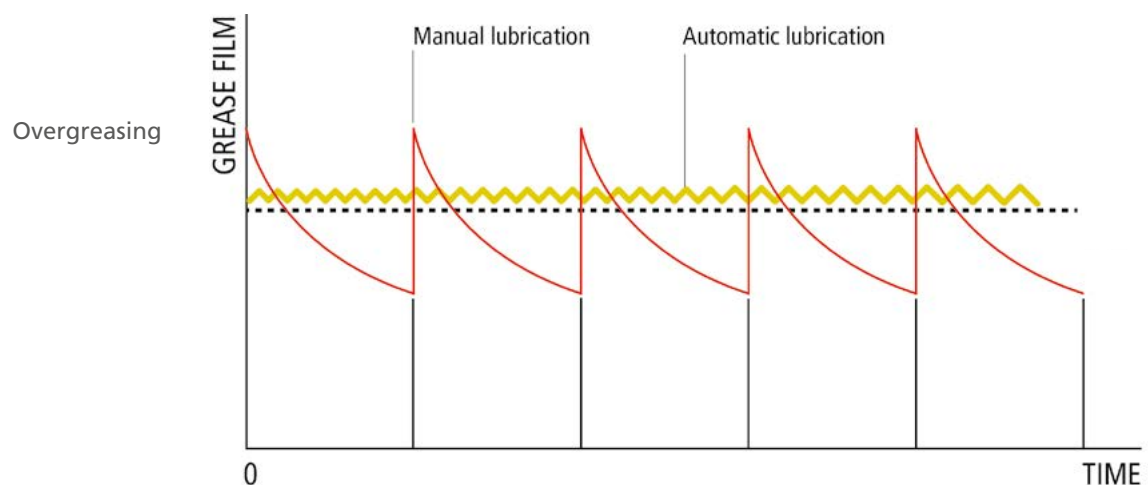

Single line systems

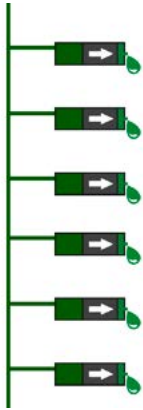

A single line parallel system can service a single machine, different zones on a single machine or even several separate machines and is ideal when the volume of lubricant varies for each point.

Each injector serves a single lubrication point, operates independently and can be individually adjusted to deliver the desired amount of lubricant.

For applications with long line lengths and a large number of lubrication points that must be greased with grease or oil a single line system is the ultimate system.

Single line systems for all kinds of applications



Trucks & Trailers



Refuse trucks



Truck mounted cranes



Low loaders



Mobile cranes



Buses



Wheel loaders (>50 tons)



Tracked excavators (>100 tons)



Dump trucks

Groeneveld SingleLine

The ultimate system for NLGI-0 grease



Groeneveld SingleLine

The combination of a strong and reliable pump and a wide range of unique metering units makes the SingleLine a highly suitable system for heavy transport equipment and buses, waste collection vehicles and port equipment. But also for industrial applications.

Independent of ambient temperature and grease viscosity, the system will apply exactly the pre-set amount of grease at each lubrication point. Long lines and large numbers of lubrication points do not pose a problem for this high quality system. The SingleLine system is available with an electrical or a pneumatic driven pump.

The system works with a relatively low pressure, preventing separation of the grease. The patented volumetric metering units ensure that the grease metering per lubrication point can be perfectly adjusted to the demand of the part to be lubricated.

- Optimum lubrication and sealing of all lubrication points
- Easy to install and to extend, quick couplings allow easy expansion of the system
- The unique metering units offer an exact and adjustable amount of grease per lubrication point
- Filler coupling with filter in order to prevent contamination of the grease during filling
- Optionally equipped with a level indicator in the grease reservoir with an active warning

System overview



Pneumatic SingleLine

Follower plate

The follower plate ensures that all the grease in the reservoir is used. This means that the reservoir wall remains clean, allowing you to check the grease level visually. Ageing of the grease as a result of oxidation is also prevented.

Reservoir

The Groeneveld SingleLine is available with reservoir volumes of 4, 6 and 8 litres.

Filler coupling with filter

The filling coupling with an internal grease filter prevents contamination of the grease during filling.

Pump housing

The pump is made of hard anodised aluminium and nylon reinforced - containing the control unit, memory database and minimum level indicator.

Electric version

For applications with their own supply of compressed air, the pneumatic SingleLine will be the perfect solution. For all applications without their own supply of compressed air, the electric SingleLine will be the right solution.

The electric version of the SingleLine is available with a 2.9 litre reservoir.



Electric SingleLine

Working principle

When the pump is activated, grease is pumped to the distribution blocks. The metering units on the distribution blocks provide the exact right amount of grease to the lubrication points via the secondary lines.

The Groeneveld SingleLine can be supplied with an electric or pneumatic pump and with an electric timer or a pneumatic brake counter. The system overview below shows a pneumatic pump with an electric timer.

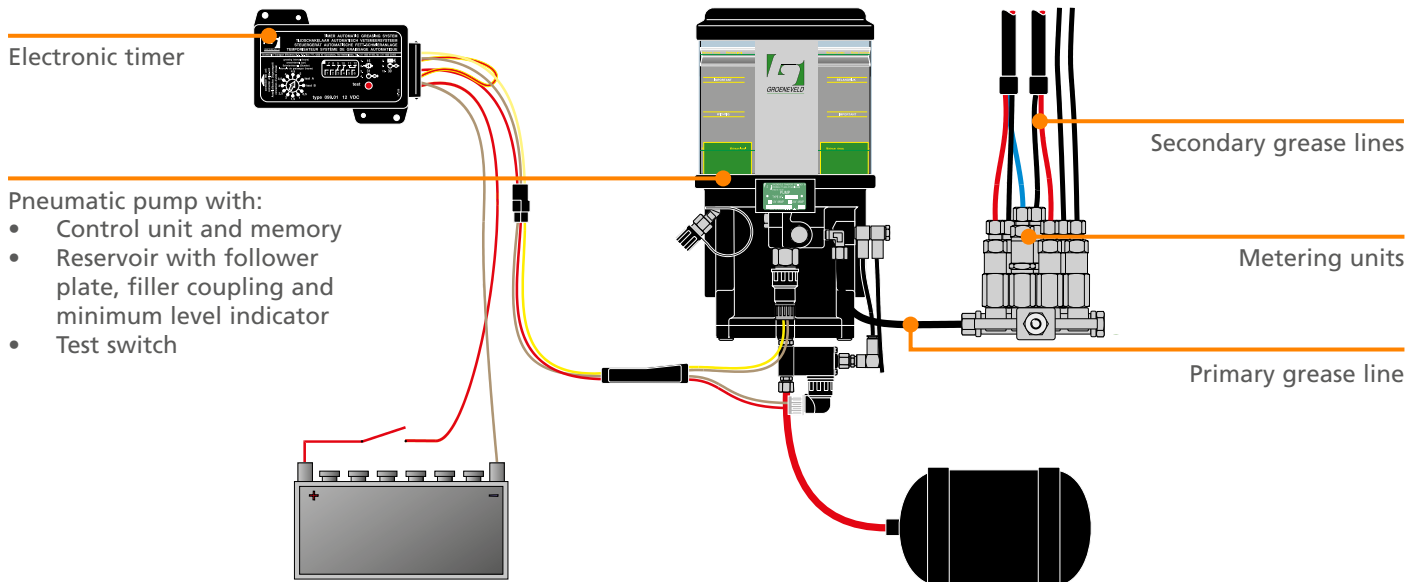

SingleLine In-cab display

With the SingleLine LED display monitoring the SingleLine system has become easy. This display is designed to be used in combination with the SingleLine timer and can easily be connected with the already present diagnostic port. On the display, that can be mounted in the cabin of the truck, all necessary system information is displayed.



Alarm speaker

Low level indicator LED

Alarm indicator LED

Grease cycle indicator LED

Select button

With the select-button a test cycle can be started via the display

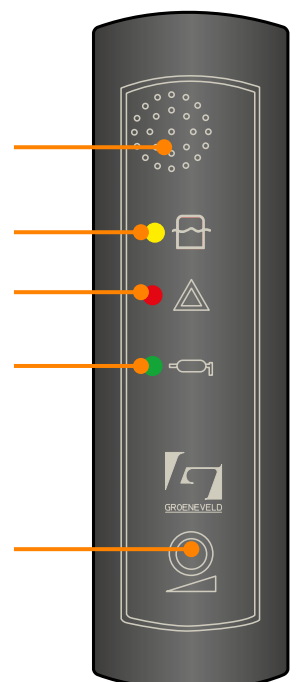



Technical information

Pump type	Pneumatic or electric
Controller	Pneumatic brake counter or electronic timer
No. of outputs	1
Maximum number or lubrication points	200*
Maximum operating pressure	250 bar (3625 psi)
Grease class	NLGI-0
Reservoir capacity pneumatic SingleLine	4, 6 or 8 litres
Reservoir capacity electric SingleLine	2.9 litres
Temperature range	-25 up to +80 °C (-13 up to 176 °F)
Supply voltage	12 or 24 Vdc
Protection class	IP54 (for pump unit)

*Depending on system resistance, grease delivery and tubing length

SingleLine display

Supply voltage	9 - 32 Vdc
Maximum operating current	220 mA
Temperature range	-30 up to +70 °C (-22 up to 158 °F)
Regulations / EMC	EN 50498:2010 EU standard aftermarket electronic equipment in motor vehicles EN 12895:2015 EU standard industrial trucks, electromagnetic compatibility

Applications

The Groeneveld SingleLine range can be used for a wide variety of applications but is most commonly used for mobile applications like trucks and trailers, busses and industrial applications.



Trailers



Tipper



Refuse trucks



Busses

BEKA STREAM

The ultimate solution for large applications



BEKA Stream

The powerful BEKA Stream is designed to provide lubricant within a central lubrication system or to single lubrication points, independent of ambient temperatures. The BEKA Stream is the ultimate solution for large applications requesting a larger amount of lubricant and is suitable for EP greases up to NLGI-2.

The system works with a relatively low pressure, preventing separation of the grease. The combination with the unique single line metering injectors ensure that the metering per lubrication point is perfectly adapted to the application.

The use of wear-resistant materials makes the seals uniquely resistant like no other on the market. This pump is not only the perfect partner in the mining sector, where tough and rough operating conditions prevail. Even when operating with lubricants containing solids, the maintenance effort remains low and simple thanks to the user-oriented design.

The Stream is available in both an electrical and pneumatic version and can be ordered together with a container or barrel. Here, optional fill level monitors ensure that refilling with lubricant can be perfectly planned.

- Available with an Electric (Stream E) or Hydro (Stream H) motor
- Robust construction ensures reliable use in mining and outdoor applications
- High delivery capacity, perfectly suitable for large applications
- Reliable lubricant supply even at extreme ambient temperatures
- Available with a wide range of reservoir capacities, as container version or barrel pump
- Easy to maintain because no oil change is necessary

System overview

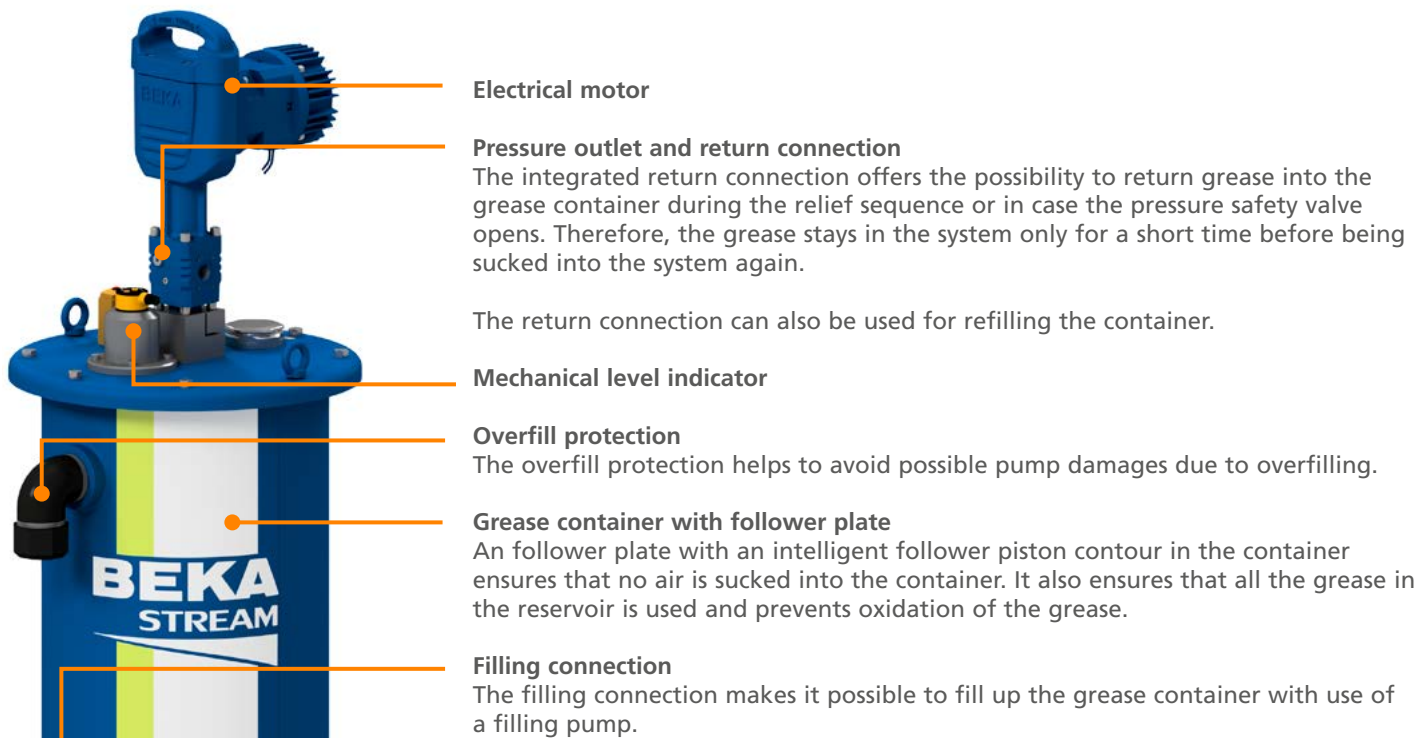

Stream E

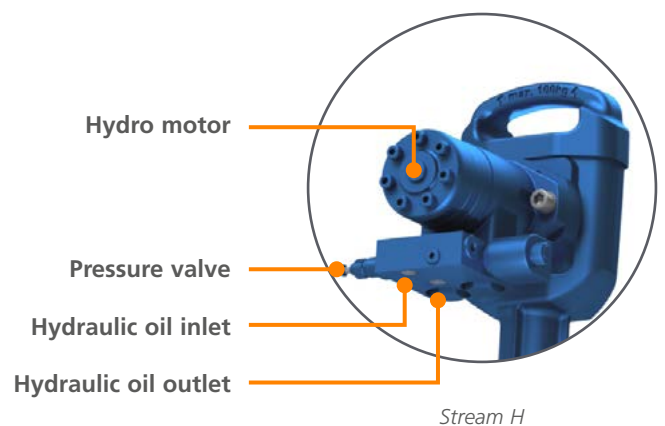

Stream H

Various options



Hydraulic drive

Brushless electric drive



Barrel version



Container version

Working principle

The Stream pumps are driven by a flanged electric motor (Stream E) or hydro motor (Stream H). The rotary motion of the motor is transformed into a stroke movement of the piston rod by an eccentric in the housing. The delivery piston of the pump is firmly connected to the piston rod, which forcibly triggers a suction and pressure stroke. Hence, the lubricant is drawn into the suction bore at the lower end of the delivery line and is delivered to the pressure outlet.

The lubrication pump of the single line system delivers the lubricant to the distributors. The system can be branched as required and can be controlled by integrated or external control units.

The BEKA Stream single line system is characterized by easy installation, operation and maintenance and can be extended as required. It is tried-and-tested in large numbers all over the world.

Applications

The BEKA Stream range can be used for a wide variety of applications but is most commonly used for large construction and mining applications like wheel loaders, excavators, dozers and graders.



Wheel loaders
(> 50 tons)



Tracked excavators
(> 100 tons)



Dozers & Graders
(> 35 tons)

Technical information

Pump type	Pneumatic or electric
No. of outputs	1
Delivery volume at 20 °C (68 °F)	Max. 120 cc/min
Maximum operating pressure	240 bar (3480 psi)
Grease class	Up to NLGI-2 without solid content
Container capacity	41, 54 or 68 liter
Barrel capacity	213 liter
Protection class motor	IP65

Stream E

Supply voltage	24 Vdc
Current consumption	Max. 15A
Temperature range	-40 up to +65 °C (-40 up to 149 °F), depending on lubricant

Stream H

Drive medium	Hydraulic oil ISO VG 46-100
Drive pressure	20 - 250 bar (290 - 3625 psi)
Return pressure	Max. 3 bar (43 psi)
Volume flow	6-12 l/min
Temperature range	-30 up to +65 °C (-22 up to 149 °F), depending on lubricant



Single line distribution blocks & metering units



Groeneveld single line distribution blocks & metering units

Various types of distribution blocks and metering units are available for the Groeneveld SingleLine system. Each grease point can receive the correct dose of grease per greasing cycle by a careful choice of the type of metering unit, which all have a different grease output.

The single line distribution blocks are built by combining a distribution block with different metering units. Unused ports on the distribution block are sealed with a blind plug. The metering units deliver the lubricant under pressure via secondary lines directly to the lubrication points.

A distribution block with metering units forms an closed structure and can therefore be fitted in a moist or dirty environment without problems.

System overview

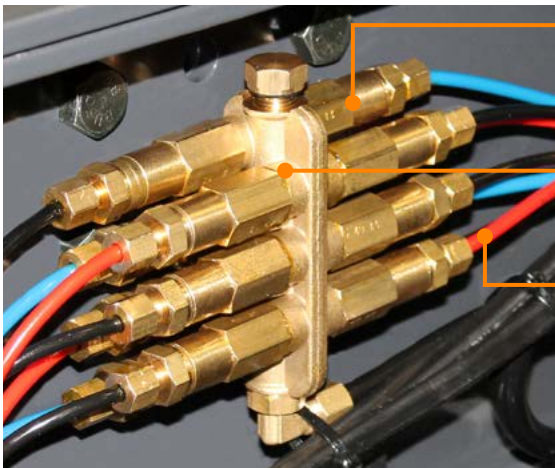

Metering unit

The various metering units are distinguished from each other using numbers. Metering units are available from 0.025 up to 4.000 cc per cycle. The metering units are available in brass or stainless steel.

Distribution block

The distribution blocks are deliverable with 1 up to 18 outlets and are available in both brass or stainless steel.

Secondary lines

The lines create the connection between the metering units and the lubrication points. From flexible hoses to very strong steel pipes, we offer the correct line for each application.

Types of distribution blocks

Groeneveld-BEKA offers different types of distribution blocks:

- Flat distribution blocks, with the metering units in one line made out of brass or stainless steel
- Distribution blocks with threaded studs, fitted with a double row of metering units made out of brass or stainless steel

Type of metering units

The metering units are available with different grease outputs and are distinguished from each other using numbers. If the largest dosing rate does not deliver sufficient grease to a grease point then it is possible to connect metering units together.

Metering unit	cc per cycle
0	0.025 cc
1	0.050 cc
2	0.100 cc
3	0.150 cc
4	0.200 cc
5	0.250 cc
6	0.300 cc
7	0.350 cc
8	0.400 cc
8.5	0.700 cc
9	1.000 cc

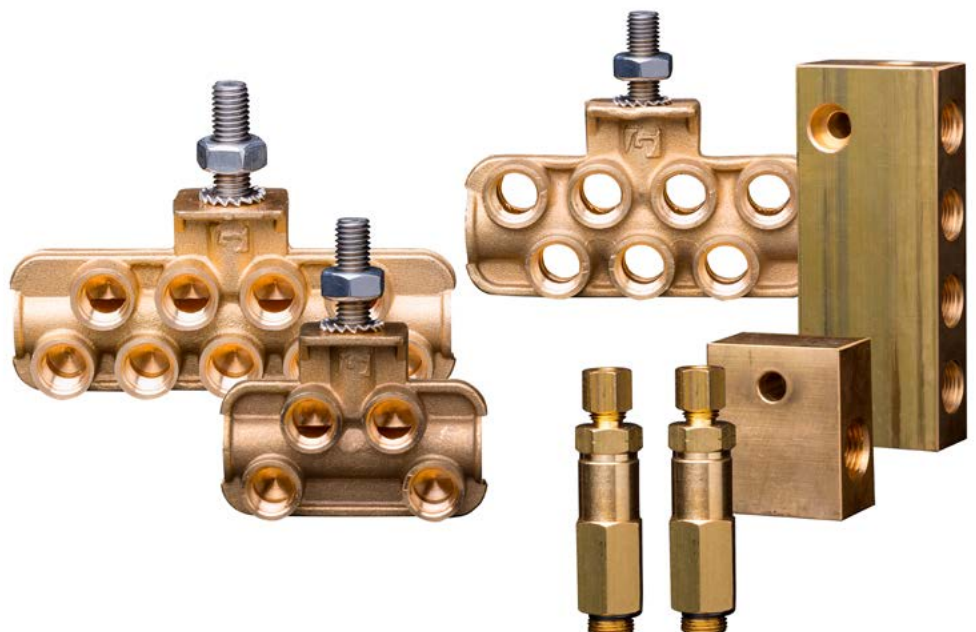

BEKA BL-1 & BL-11 metering injectors

Metering distributors BL-V and BL-V XL are designed for use in single line systems. They operate according to the static principle.

The BEKA BL metering injectors for single line systems are available in 2 sizes; the BL-1 and BL-11. The BL-1 is available with up to 6 metering valves per manifold. The BL-11 has a single outlet.

The BL-1 single line distributors delivers the lubricant under pressure via lines directly to the lubrication points. One lubrication point can be assigned to one or more metering valves. Metering can be adjusted for each lubrication point at each distributor, respectively each metering valve.

The metering volume of the BL-11 metering valve can be adjusted infinitely.

A protective cap for the set screw as well as metering sleeves for quicker metering volume adjustment can be ordered optionally.

- Compatible with different types of distributors
- For lubricants with high viscosity
- Easy adjustment
- Visual monitoring

System overview BL-1

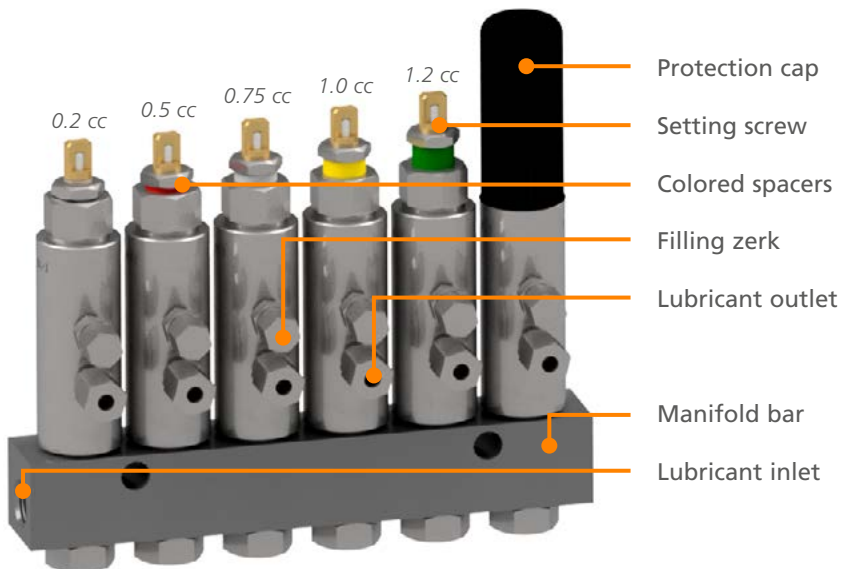

System overview BL-11

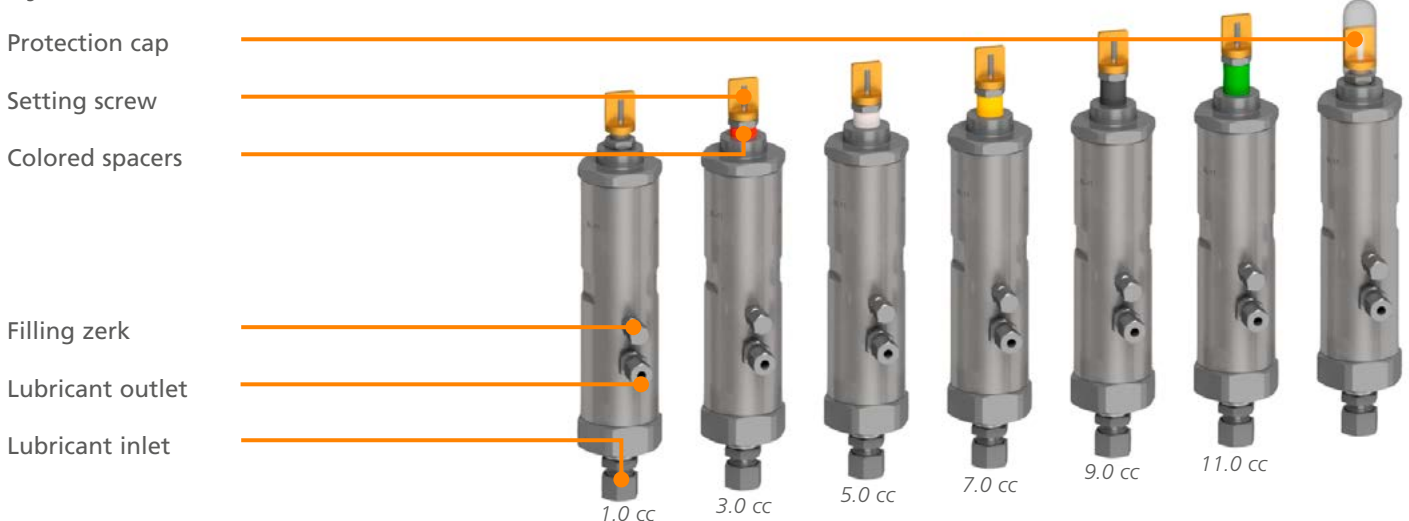



Technical information

BL-1

Operating pressure	Min. 140 bar (2030 psi) Max. 240 bar (3480 psi)
Relief pressure	< 50 bar (725 psi)
Temperature range	-26 up to 90 °C (-14 up to 194 °F), depending on lubricant
Lubricant	Oil, fluid grease, grease up to NLGI-2
Metered volume	Adjustable between 0.2 to 1.2 cc per stroke and outlet
No. of outlets or metering valves per manifold	Min. 1 Max. 6
Material	Steel, corrosion protected

BL-11

Operating pressure	Min. 70 bar (1020 psi) Max. 240 bar (3480 psi)
Relief pressure	< 55 bar (797 psi)
Temperature range	-40 up to 93 °C (-40 up to 199.4 °F), depending on lubricant
Lubricant	Fluid grease, grease up to NLGI-2
Metered volume	Adjustable between 1.00 to 1.20 cc per stroke and outlet
Material	Steel, corrosion protected